

WALLVIEW™ 50i PTZ HIDEAWAY

INSTALLED PTZ WALL CAMERA WITH MOTORIZED IN-WALL CAMERA LIFT SYSTEM

Vaddio's WallVIEW 50i PTZ HideAway Camera System is designed to provide system integrators with an easy to install in-wall motorized camera lift system. The system features a Canon® VC-C50i PTZ Camera mounted into a recessed plenum rated wall camera enclosure that has a



WallVIEW HideAway-OPEN

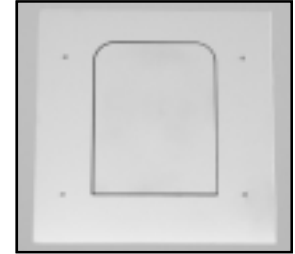

WallVIEW HideAway-CLOSED

motorized front panel. When closed, it conceals the camera and when the camera is activated the front door drops down and reveals the camera. The camera's IR remote control, contact closure or voltage sensing can be used to trigger the system. The system is equipped with Vaddio's EZCamera™ Cabling System, which allows the installer to use Cat. 5 cabling to run power, video and camera control. An optional VISCA control interface can be added to allow the camera to work with any VISCA compatible control device.

WHAT'S INCLUDED

The Vaddio WallVIEW 50i HideAway includes the following items:

- Canon VC-C50i PTZ Camera
- Canon Multi-Function Remote Control
- Recessed wall-mount enclosure with power lift door and camera mount
- EZCamera Camera Shoe Interface
- EZCamera Quick-Connect Box
- EZCamera Control Adapter
- 50 feet Cat. 5 cabling with RJ-45 jacks
- PowerRite™ Power Supply
- 15 foot S-Video cable
- 15 foot composite video cable
- All screws and mounting hardware

TECHNICAL FEATURES

Canon VC-C50i PTZ Camera

A wall-mountable PTZ camera equipped with a 26X optical and 12X digital zoom lens. The VC-C50i delivers high quality video from far distances and under the dimmest lighting conditions. Building on Canon's long-standing tradition as the leader in optics and image processing, it offers greater flexibility in the most demanding environments. Camera features include: Nine camera presets, auto-focus, auto-

iris, and one lux minimum illumination. The motorized pan has a range of 100 degrees each way and the tilt has a range of 90 degrees up and 30 degrees down.

HideAway Camera Enclosure

The WallVIEW 50i PTZ HideAway Camera Enclosure is designed to fit flush into a wall. With its thin profile design this camera system can be installed into any wall with four inches of clearance. The wall box has flanged ears on the side with four screw holes that mounts the box to the wall with anchors and screws. A trim ring covers the sides of the enclosure and provides a finished appearance. The motorized front metal door of the enclosure is hinged from the bottom and has a smooth powdercoat finish on the front. The front panel is designed to drop down and reveal the camera that is mounted on the back. The back of the front panel has a tripod screw which secures the camera to the door. The panel opens when the camera is activated and closes when the camera is finished.

EZCamera Cabling System

Allows installer to use Cat. 5 cable to run power, video and camera control. Video Balun technology is used to extend the range of the video signal and to allow it to work on Cat. 5 cable. The Vaddio PowerRite Camera Power System includes a

(continued)

TECHNICAL FEATURES (CONTINUED)

high output power supply and a power regulator to maintain the right voltage over Cat. 5 cable.

EZCamera Shoe Interface

A plug-in shoe that intergrates the Canon VC-C50i PTZ Camera to the EZCamera Cable System. The shoe interface converts camera outputs to three RJ-45 jacks. The first jack provides power and video. The second jack provides primary camera control signaling and the third provides daisy-chain camera control to additional Canon PTZ Cameras.

EZCamera Quick-Connect Box

This small interface box converts power, S-Video and composite video into a single Cat. 5 cable. Velcro® mounting square provided.

VISCA Camera Control Option

The system can be ordered with VISCA camera control. This allows you the ability to use the camera system with control systems and video codecs that support the VISCA protocol. The system ships standard with the Canon instruction set.

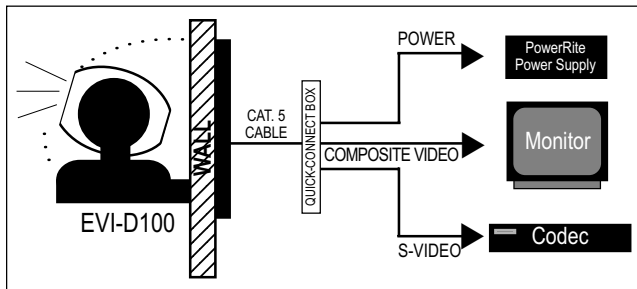

Figure 1 – EZCamera cable system with a quick-connect single gang wallplate/quick-connect box.

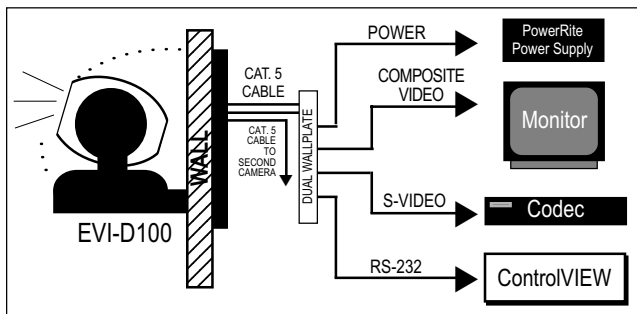

Figure 2 – EZCamera cable system with a quick-connect dual gang wallplate.

TECHNICAL SPECIFICATIONS

Optics	
Lens Configuration	Nine(9) Groups of Eleven(11) Lens
Focal Length & F Number	f=3.5 to 91mm; F1.6 to F4.0
Marginal Lumination Ratio	30% Over
Zoom Ratio	26X (at infinite)
Focus Region	Wide: 0.01m to ∞; Telephoto: 1.6m to ∞; Auto/Manual
Horizontal	42° Wide; 1.7° Telephoto
Imaging	
Imaging Device	1/4" CCD
Number of Pixels	NTSC – 630K Total (340K effective); PAL – 740K Total (400K effective)
Color Separating System	Secondary Mosaic Filter System
Electronic Shutter Speed	NTSC – 1/80,000 - 1/60 - 1/1 sec; PAL – 1/80,000 - 1/50 - 1/1 sec
Imaging Mode	Visible Light Mode; Infrared Light Mode
Minimum Subject Illumination	1 lx (visible light mode, at 1/30 electric shutter speed)
Infrared Lighting	GaAIs Infrared Radiation LED; Four Piece
Infrared Light Power	About 0.75 W x 4
Infrared Light Wavelength	970nm (peak value)
Video	
Color System	NTSC/PAL (depending on the country of use)
Luminance Signal S/N ratio	50dB
Resolution	Horizontal: 460 TV Lines; Vertical: 350 TV Lines
Scanning System	Interlace
White Balance	Auto/Manual/One-push
Character Display	Setting, Clock
Mechanism	
Pan Angle Range	VC-C50i – ±100°; VC-C50iR – ±170°
Tilt Angle Range	VC-C50i – -30° to +90°; VC-C50iR – -90° to +10°
Rotation Speed	Pan: 1 to 90°/s; Tilt: 1 to 70°/s
Infrared Cut Filter	Motor Driven (visible light mode/infrared light mode)
Preset Function	Nine(9) Positions
Cascade Control	Nine(9) Cameras
Connectors	
BNC	Composite Video Output
Multiconnector	S-Video Output, RS-232C Control (input, output), Other
DC Input	Custom Jack (AC adapter is used)
Regulation	
Wide Converter Connection	Diameter: 37mm; Pitch: 0.75mm
Voltage of Operation	DC 13 V (AC adapter is used)
Power Consumption	13 W
Power Supply	100 - 240V
Other	
Operating Temperature	32° F (0° C)
Dimensions	Depth: 4.48"/113mm Width: 4"/101mm Height: 3.58"/90mm
Weight	14.3oz/405g

vaddio

4800 Quebec Avenue North Minneapolis, MN 55428
Toll Free: 800.787.8078 • Phone: 763.537.3601 • Fax: 763.537.2852
www.vaddio.com